



*All Saints Episcopal Church*

Candlelight Tour of Historic Houses of Worship  
Friday, December 26, 2025

**Welcome to All Saints and Merry Christmas! We hope you are inspired by the architecture, windows, seasonal decorations, and music that surround you this evening. We are thankful that you are here.**

***Refreshments are available upstairs in the Great Hall.***

*All Saints offers a radical welcome to ALL people regardless of race, gender identity, differing abilities, political affiliation, creed, or class, recognizing that we are called to pursue justice and advocate for the vulnerable. To find out more about the ways in which we actively live out our faith, please see the Community tab of our website: [www.allsaintsmd.org](http://www.allsaintsmd.org).*

### **History of All Saints Episcopal Church**

Founded in 1742—three years before the city of Frederick itself—All Saints began by act of the colonial government in Annapolis. We are proud to be the oldest Episcopal church in Western Maryland. Our present building on West Church Street, completed in 1855, is the third home of the parish. Designed in the Gothic Revival style by noted New York architect Richard Upjohn, the church features a long, graceful nave with side aisles, a recessed chancel, and a soaring bell tower and spire. Our spire is among those that help form the “Clustered Spires” celebrated by poet John Greenleaf Whittier. If you’re nearby on a Sunday morning, listen for our bells ringing out across the city.

The parish’s first building, erected in 1750, once stood on East All Saints Street, about four blocks from the current church, but was later demolished. Our second church, built in 1814 on North Court Street, still stands and now serves as our Parish Hall and classrooms. None of the stained-glass windows in the current sanctuary are original; all were installed later. The oldest—shimmering above the altar—were crafted in Bavaria in 1910.

All Saints played a dramatic role during the American Civil War. Both the second and third church buildings were used as field hospitals, caring for wounded soldiers from the battles of South Mountain and Antietam. The parish altar even served as an operating table—its wood said to bear indelible stains from those desperate days. Today, that altar is preserved in the Great Hall. The former Rectory at 108 West Church Street also supported the war effort, serving as a military headquarters early in the conflict.

The history of women in our parish reflects broader strides toward equality. Women gained the right to vote in parish elections in 1940 and became eligible for election to the Vestry in 1970. The Episcopal Church formally approved the ordination of women in 1976, and All Saints welcomed its first female priest in 1983. Today, we are honored to be led by The Rev. Catherine M. Thompson as our Rector.

Throughout the centuries, All Saints has welcomed a remarkable array of parishioners and visitors. Among the distinguished figures connected with our church are Francis Scott Key; Maryland’s first governor, Thomas Johnson; William Pendleton (Staff General and Rector to Robert E. Lee); William Delaplaine, founder of *The Frederick News-Post*; U.S. Senator Charles McC. Mathias; and U.S. Representatives Goodloe E. and Beverly B. Byron.

### ***Candlelight Tour Schedule***

<b>3:00 – 4:00</b>	Seasonal Music
<b>4:00 – 5:00</b>	All Saints Ringers & All Saints Choir
<b>5:00 – 6:00</b>	Harpist – Anna Smith
<b>6:00 – 7:00</b>	The Joybells – Carroll Howe, <i>Director</i>
<b>7:00 – 8:00</b>	Seasonal Music

# *All Saints Music Ministry Program*

4:00 – 5:00

*All carols can be found in the blue Hymnal 1982 located in your pew rack.*

<b>Opening Carol</b>	<i>O Come All Ye Faithful</i>	<b>No. 83</b>
<b>Choir</b>	<i>Joy to the World</i> <i>The First Nowell</i>	Traditional David Willcocks
<b>All Saints Ringers</b>	<i>He is Born</i> <i>Angels Singing, Tiding Ringing!</i> <i>Ding Dong! Merrily On High</i>	arr. Sondra K. Tucker Douglas E. Wagner arr. Cynthia Dobrinski
<b>Choir</b>	<i>Deck the Hall</i> <i>Jingle Bells</i> <i>Ave Maria</i>	Traditional J. Pierpon Jacques Arcadelt
<b>Carol</b>	<i>Angels We Have Heard On High</i>	<b>No. 96</b>
<b>All Saints Ringers</b>	<i>The First Noel/Silent Night</i> <i>Joyful and Triumphant!</i> <i>Carol of the Bells</i>	arr. Michael Bedford Douglas E. Wagner arr. Jason Krug
<b>Choir</b>	<i>Ding Dong! Merrily on High</i> <i>In the Bleak Midwinter</i> <i>The Holly She Bears a Berry</i> <i>O Shepherds Aren't You Happy</i>	Charles Wood Harold Darke James E. Clemens Hal H. Hopson
<b>Closing Carol</b>	<i>Hark! The Herald Angels Sing</i>	<b>No. 87</b>

*Please join us at any of our regularly scheduled services!*

## Sundays

8:00 a.m. – Holy Eucharist, Rite I (*no music*)  
9:00 a.m. – Fellowship and Christian Formation  
10:00 a.m. – Holy Eucharist & Choral Mass, Rite II  
11:00 a.m. – Fellowship and Youth Group

## Mondays through Thursdays

7:30 a.m. – Morning Prayer

## Wednesday Evenings

5:30 p.m. – Healing Service with Holy Eucharist

## Saturdays

8:30 a.m. – Centering Prayer Group



VISIT US ONLINE!

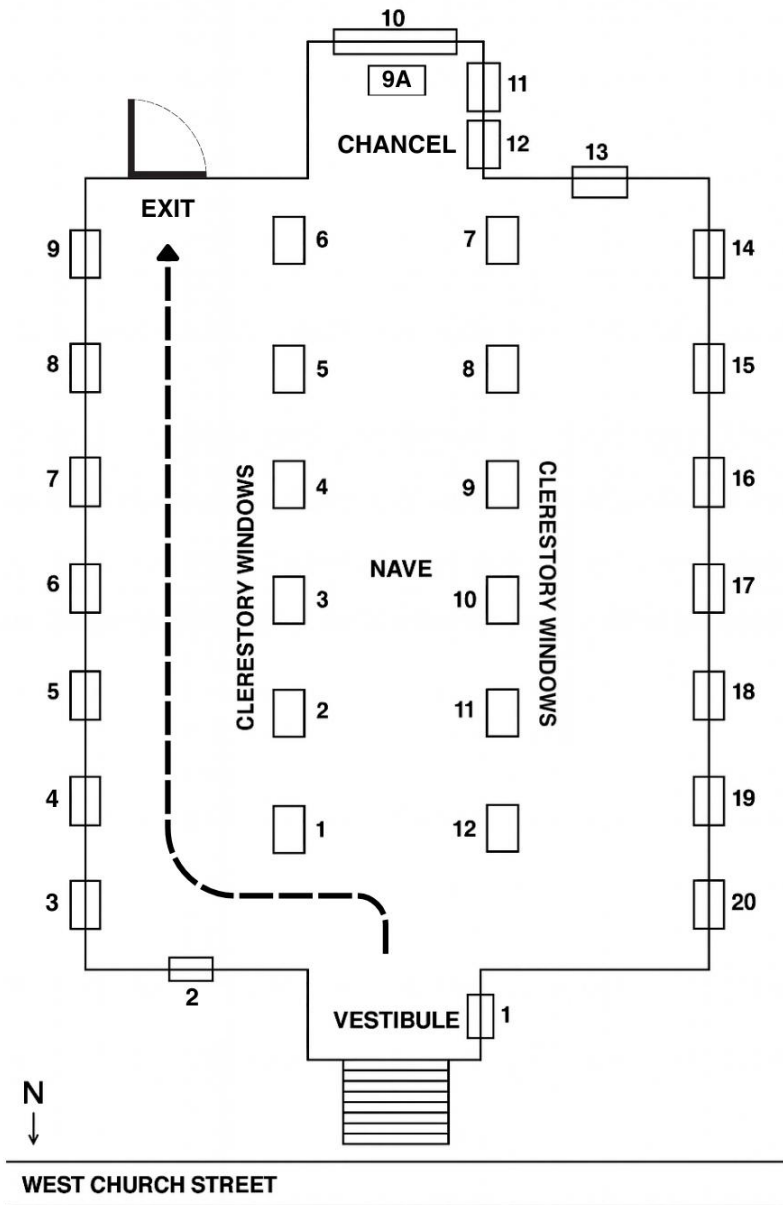

1. Three scenes of the Virgin Mary
2. Children presenting flowers to Jesus
3. Archangel Gabriel appearing to Mary
4. Jesus: "Come unto Me."
5. Angel with Lillies
6. Virgin Mary; infant Jesus benediction
7. Jesus the Good Shepherd
8. Mary weeping before the tomb
9. St. Monica and St. Augustine of Hippo
- 9A. The Last Supper Tablet
10. Windows over the High Altar, Te Deum
  - L. The New Testament
  - C. Christ, the Great High Priest
  - R. The Old Testament
11. Risen Lord, above a Roman soldier
12. Angel in pink, holding a lily
13. "...the little children, come unto Me:"
14. Faith, Hope, and Charity, a mother teaches
15. Jesus heals the disabled person
16. Glory to God in the Highest
17. Three scenes by artist George Foertsch
18. "Honor thy Father and thy Mother"
19. The Virgin Mary and the Infant Jesus
20. St. John the Evangelist

**Medieval Style**

1-2, 9, 13, 15-20

**In the style of Louis C. Tiffany**

3-5, 7

**Modern or Victorian Painted-Glass Style**

6, 8, 10-12, 14

**CLERESTORY WINDOWS**

- |                 |                         |
|-----------------|-------------------------|
| 1. St. Peter    | 7. St. Matthew          |
| 2. St. Andrew   | 8. St. James the Less   |
| 3. St. Philip   | 9. St. Jude             |
| 4. St. Matthias | 10. St. Bartholomew     |
| 5. St. Thomas   | 11. St. James the Great |
| 6. St. Barnabas | 12. St. John            |

**Upcoming Events in 2026**

Free Concert: The U.S. Army Chorus | 3:00 p.m.  
 Candlemas Service, 5:00 PM, Fire & Ice  
 Ash Wednesday, 7:30 AM, 12:00 PM, 7:00 PM  
 Maundy Thursday, 7:00 PM  
 Good Friday, 12:00 PM & 7:00 PM  
 Easter Day, 8:00 AM and 10:00 AM

January 11<sup>th</sup>  
 February 7<sup>th</sup>  
 February 18<sup>th</sup>  
 April 2<sup>nd</sup>  
 April 3<sup>rd</sup>  
 April 5<sup>th</sup>